

Specifications — PCA 100 Pipe Coupling Adapter

General

Maximum load capacity 200 lbs
Material Steel
Dimensions 2.1" long x 2.2" O.D.
5.2 cm long x 5.6 cm O.D.
with 11.5 NPSC internal pipe threads

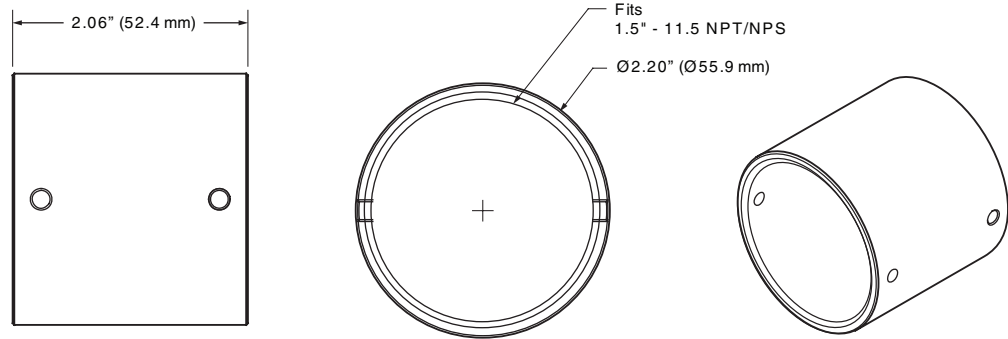

NOTE The PCA 100 accepts a 1.5" diameter (o.d.), 11.5 NPT/NPS extension column.

Product weight 0.3 lb (0.2 kg)
Shipping weight 1 lb (1 kg)
Vibration ISTA 1A in carton (International Safe Transit Association)
Listings UL, CUL
Compliances CE
Warranty 3 years parts and labor

NOTE Specifications are subject to change without notice.

(7.52-102507-D2)